

# DS Series

DS-1600 DS-1800

Mimaki

## Direct Dye-Sublimation System

"Print quality is up, costs come down,  
DS series came to get the answer: Direct Print onto media"

"Introducing a high resolution system which is more ecologically friendly and provides more efficient operation as compared to traditional sublimation transfer systems."



### High, sharp print quality

Direct printing provides fine lines and sharp edges compared to using transfer system.

### Environmental-friendly

No need to use transfer paper.

### Reduced cost

This system requires no transfer paper or liner paper. Its running costs are much lower than the cost of traditional transfer systems.

### Improved efficiency of the operation

The system avoids cockling of printed transfer paper and mistakes made by wrinkling transfer paper when transferring the ink onto fabric.



## Direct dye-sublimation printing system

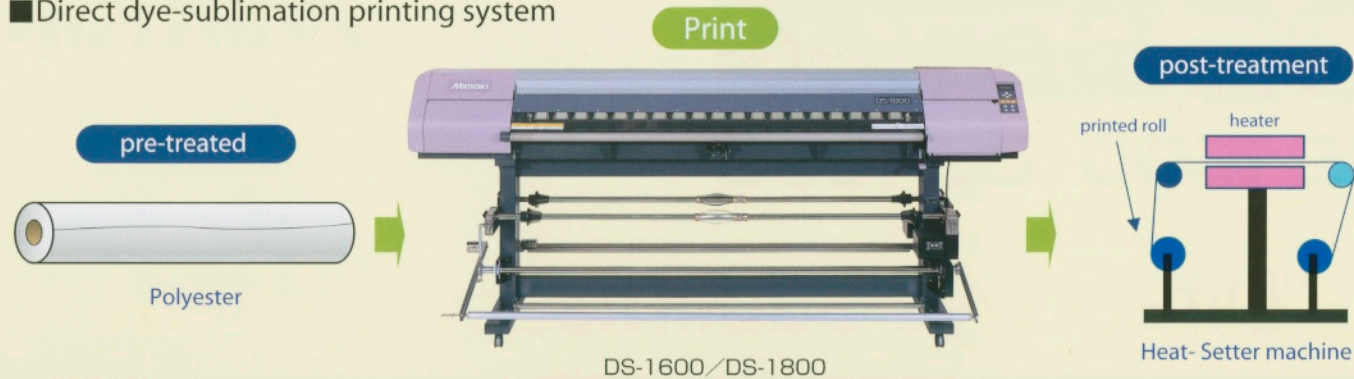

### Equipped with media take-up device and media feeder with a dancer roller

The tension bar moves up and down to adjust proper feeding. Suitable for continuous operation.

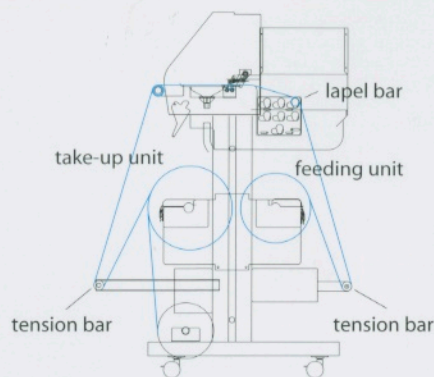

### Fabric supply mechanism

In addition to the drive roller and friction roller, the take-up unit and feeding unit with a dancer roller cause tension in the fabric to prevent it from wrinkling. The fabric retainer holds both edges of the fabric preventing it from touching the print head.



### Ditch for penetrated ink

In order to prevent ink from penetrated the fabric from marking other fabrics, a ditch is available.



### High-speed print heads

The head configuration employs array of two staggered print heads. 1-way (single ink set) for fast printing and 2-way (dual ink set) for multi-purpose printing are available. In addition both print modes can use either high speed print of 4-color or high quality print of 6-color.

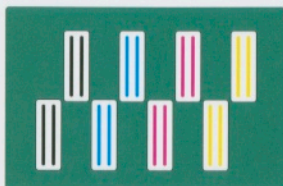

### Specifications

Item	DS-1600	DS-1800	
Method	Piezo-electric drop on demand		
Printing head	Nozzle configuration Eight heads (4 x 2 lines, stagger arrangement)		
	Number of nozzles <6-color print> 1-way: 360 nozzles 2-way: 180 nozzles		
	<4-color print> 1-way: 720 nozzles 2-way: 360 nozzles		
Resolution	360, 540, 720 dpi		
Maximum printing width	1620mm (63.7")	1850mm (72.8")	
Head height adjustment	1.2mm (0.04") to 10mm (0.39")		
Print Modes 1*)	360 x 360 dpi : 2/4/8 passes, unidirection/bidirection		
	6-color printing		
	360 x 540 dpi : 3/6/12 passes, unidirection/bidirection		
	360 x 720 dpi : 4/8/16 passes, unidirection/bidirection		
	720 x 720 dpi : 4/8/16 passes, unidirection/bidirection		
	4-color printing		
360 x 360 dpi : 1/2/4 passes, unidirection/bidirection			
360 x 540 dpi : 3/6/12 passes, unidirection/bidirection			
360 x 720 dpi : 2/4/8 passes, unidirection/bidirection			
720 x 720 dpi : 2/4/8 passes, unidirection/bidirection			
Ink type	Sublimation dye ink	Color (black, cyan, magenta, yellow, light cyan, light magenta)	
	Textile pigment ink	Color (black, cyan, magenta, yellow)	
Ink volume	6 color print 1-way: 220cc x 2/color, 2-way: 220cc x 1/color 2*)		
	4 color print 1-way: 220cc x 4/color, 2-way: 220cc x 2/color		
Fabric	Type	Polyester / Cotton 3*)	
	Width	200mm (7.8") - 1650mm (64.9") 200mm (7.8") - 1900mm (74.8")	
	Thickness	less than 7mm (0.27")	
	Outside diameter	less than ø 250 mm (9.84")	
	Roll weight	less than 30kg (66lbs)	
	Roll inside diameter	1.5" - 3"	
	Printing surface	Printing can be made on either side	
	Roll end treatment	Light adhesive tape is used to allow the paper to be removed	
	Margin (roll fabric)	10mm (0.39") ± 0.5mm (0.01"), left side and right side	
	Interface	IEEE 1394, IEEE 1284	
Command	MRL-1E (ESC/PV.1 base) Mimaki original command		
Operational environment	Temperature	15 °C ( 55°F ) - 30 °C ( 86°F )	
	Humidity	35 - 65 % Rh ( no condensation )	
Power	AC 100 - 240 V ± 10% ( auto voltage ), 50/60 Hz ± 1 Hz		
Power consumption	less than 500W		
Weight	230kg (507lbs)		
	250kg (551lbs)		
Outside dimensions	Width	2750mm (108.3") 3040mm (119.7")	
	Depth	940mm (37.0")	
	Height	1350mm (53.2")	

1\*) Some combinations of pass drawing direction, scan speed and resolution may not be supported.  
2\*) capacity of textile ink cartridge is 210cc.  
3\*) Any fabric that expands/shrinks with moisture or stretches cannot be used.

Specifications are subject to change without notice due to technical improvements, etc.  
DS18V1.0106

## MIMAKI ENGINEERING CO., LTD.

TKB Gotenyama Bldg. 5-9-41 Kitashinagawa Shinagawa, Tokyo 141-0001, Japan Tel: +81-3-5420-8671 trading@mimaki.co.jp www.mimaki.co.jp

## MIMAKI USA, INC.

140 Satellite Boulevard NE, Suwanee, Georgia 30024-7128 Atlanta +1-888-530-3988 Boston +1-888-530-3986 Los Angeles +1-888-530-3987 Chicago +1-888-530-3985 www.mimakiusa.com

## MIMAKI EUROPE B.V.

Joan Muyskenweg 42-44, 1099CK Amsterdam, The Netherlands Tel: +31-20-4627-640 www.mimakeurope.com



All our products are manufactured under our quality assurance system certified by ISO9001

printed in Japan DB3-0242-01